

TURNSOLE
Powered by OMRON

THE ULTIMATE PLUG-AND-PLAY TRACKING SYSTEM



3GW
PROJECTS SUPPLIED



2.2GW
DEVELOPMENT EXPERIENCE



10+ YEARS
EXPERIENCE IN SOLAR



20+ OFFICES
ACROSS 5 CONTINENTS



2,500
QUALIFIED SOLAR INSTALLERS



DEVELOPED WITH OVER A DECADE OF TRACKER EXPERIENCE

TURNSOLE Powered by OMRON is a fully integrated project solution, based on a horizontal single axis tracker system, engineered and optimised using world-class PV components (modules, inverters and BOS). The technology has evolved from a combination of more than 10 years' tracker and 80 years' electronics experience. Developed in partnership with OMRON, the Japanese leader in power electronics, our TURNSOLE solution embodies technological advancement focusing on robustness and reliability.



ABOUT PROINSO

PROINSO is a global leader in the solar energy market offering a full-service portfolio for solar projects of all scales including: advisory, procurement, engineering, project development, finance and construction. Since our establishment in 2006 PROINSO has supplied over 3GW of projects for blue-chip companies and governments and has operations on 5 continents. PROINSO is a recipient of the 2018 Queen's Award for Enterprise, the highest accolade for business success in the UK, in recognition of its outstanding performance.



ROBUST & RELIABLE

Our tracking solution combines engineering expertise from PROINSO's long-term strategic supply partners, all global leaders in their respective technologies.



INCREASED YIELD

Our tracking system will increase energy yield on your projects by up to 25% (compared to fixed-structure installations).



ONE-STOP-SHOP SOLUTION

TURNSOLE Powered by OMRON is more than a tracker. This powerful tracking system is fully integrated using world-class solar PV components.



REDUCED INSTALLATION COSTS

Our ready-to-use tracker will lessen installation and maintenance time. Simplified installation of TURNSOLE Powered by OMRON tracking system will result in lower man-hours, while optimised foundation design reduces civil work costs.



FIT FOR ALL TERRAINS

Thanks to its optimized design featuring 40 panels in a single line, TURNSOLE Powered by OMRON has a high degree of flexibility, which makes it suitable for even the most complicated shaped terrains.



GLOBAL INSTALLATION & SERVICE

We are proud of our exclusive network of Qualified Installers who demonstrate technical expertise and comply with the highest professional standards in the industry.

THE ULTIMATE PLUG-AND-PLAY TRACKING SYSTEM

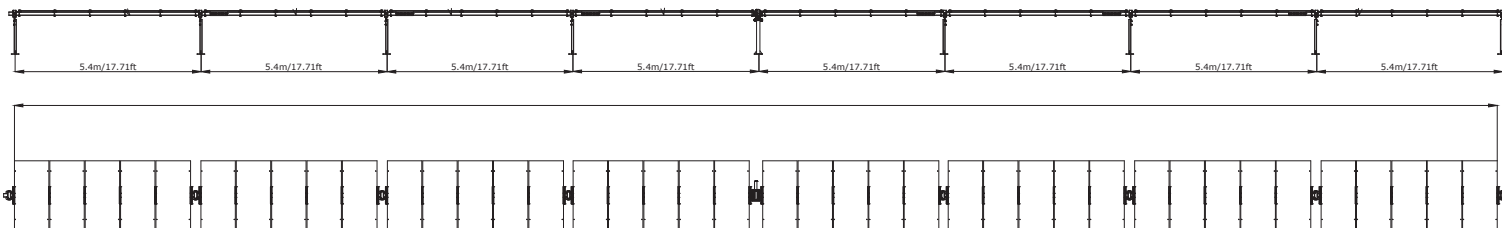

MAIN FEATURES

TRACKER TYPE	Horizontal Single Axis
TRACKING RANGE	110 degrees (± 55 degrees)
MAXIMUM ROW SIZE	40 Modules
DRIVE MOTOR	Slew Drive, 24 V DC Motor
DC CAPACITY	Up to 13 kW
SYSTEM VOLTAGE	1000 V and 1500 V Options (Depending on System Design)
SUPPORTED MODULES	Standard: 72 cells / Optional: 60 Cells
FOUNDATION TYPES	Rammed Pile / Piles Embedded / Screw / Concrete
N-S TOLERANCES IN SLOPE	10%
E-W TOLERANCES IN SLOPE	No Restrictions
WIND LOADS	160 km/h (99.4mph) up to 190 km/h (118mph)
OPERATING TEMPERATURE RANGE	From -40° to $+80^{\circ}$
MATERIALS	HDG S275/S355 or Similar and Aluminium T5
TYPICAL DIMENSIONS	Width: 2.1 m (6.9ft) / Length: 42 m (137.8ft) / Height: Flexible

TURNSOLE

Powered by OMRON

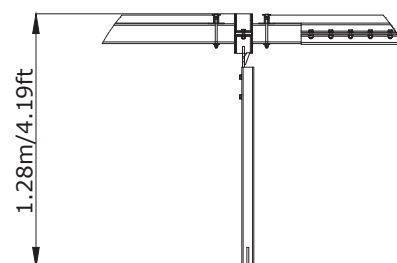

CONTROL SPECIFICATIONS

SOLAR TRACKING ALGORITHM	Astronomical with Backtracking Option
CONTROL ELECTRONICS	OMRON Control System
IP MARKING (FIRE PROTECTION)	IP65
HARDWARE MARKING	8.8 Grade
SENSOR	Inclinometer
WIND PROTECTION	3 Adjustable Wind Alarms

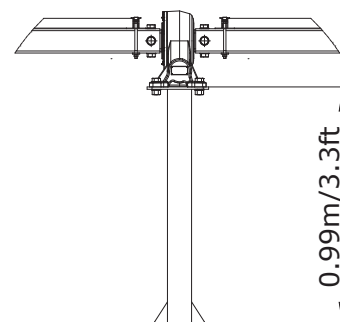

COMMUNICATION

WIRED	RS485/Ethernet
--------------	----------------

OTHER SERVICES

SYSTEM CONFIGURATION	YES
TRAININGS WORLDWIDE	YES
TRACKER INSTALLATION	YES
OPERATIONS & MAINTENANCE	YES
TECHNICAL SUPPORT WORLDWIDE	YES

WARRANTY

STRUCTURE	10 years
MOTOR	5 years

PROINSO HQ

943 Yeovil Road
SL1 4NH Slough
UNITED KINGDOM
info@proinso.net
+44 (0)1753 538 448

PROINSO SOUTH AFRICA

7th Floor, Mandela Rhodes Place,
Cnr of Wale and Burg Street,
Cape Town, 8000,
South Africa
southafrica@proinso.net
+27 (0)21 410 8908

PROINSO AMERICAS

1030 Riverside PKWY Suite 130
West Sacramento
CA 95605, United States
promotions@proinso.net
+1 (0)916 374 8722

PROINSO EAST ASIA

15th Floor, 100 Queen's Road
Center Central, Hong Kong
china@proinso.net
+852 (0)39 606 363

PROINSO SOUTH ASIA

2-22 Evergreen Industrial
Estate Shakti Mill Lane
Mahalaxmi
400011 Mumbai, India
india@proinso.net
+91 (0)22 4004 2286